

FABBRICATORI DI GHIACCIO GRANULARE PRESSATO
 MACHINES À GLACE EN GRAINS PRESSÉE
 ICE FLAKE MACHINES - PRESSED ICE FLAKES
 FABRICADORES DE HIELO GRANULAR PRENSADO
 EISFLOCKENBEREITER GEPRESSTE EISFLOCKEN

ASGP 78

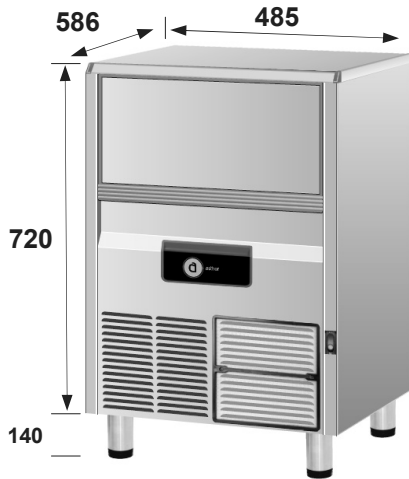

Stainless steel AISI 304

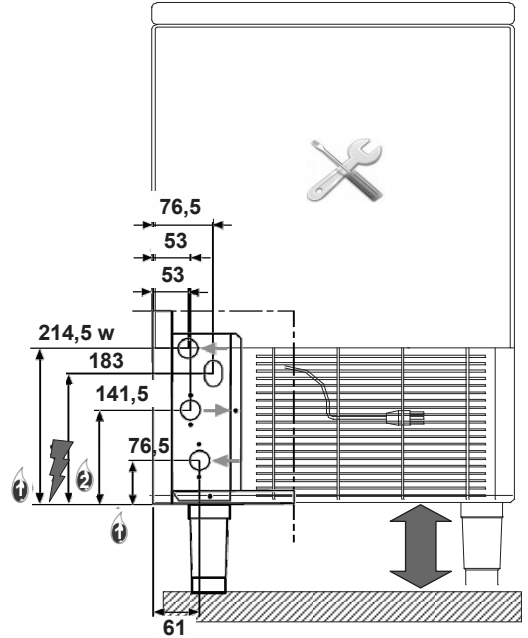

L=1800 mm		
ø 3/4"		
ø 3/4"		
130÷140 mm		

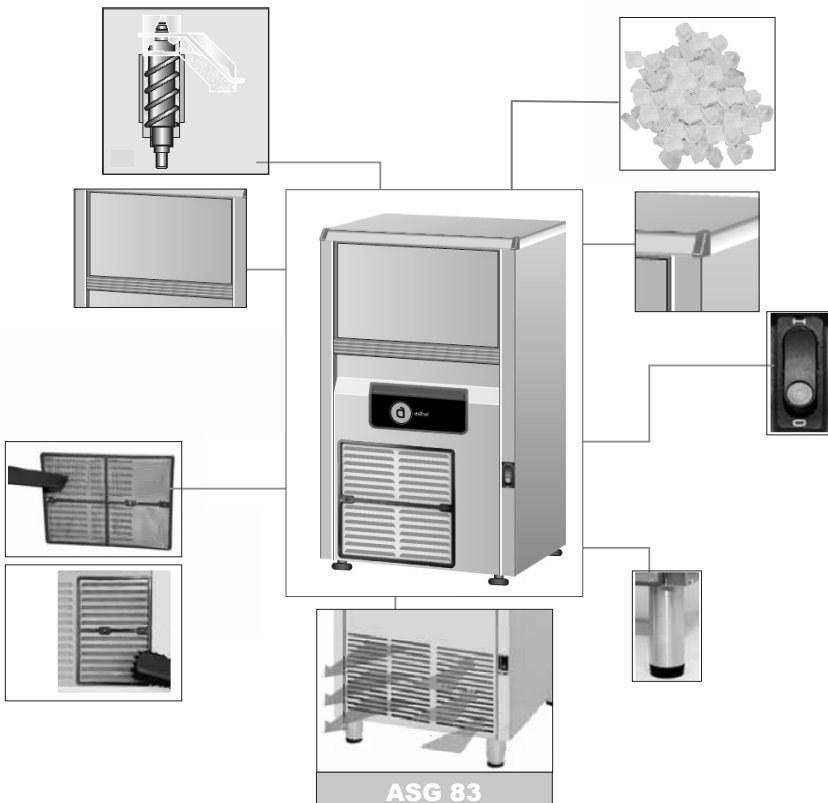

Kg / 24h - Air				
← →				
	38°	49	32°	
	32°	55	21°	
	21°	69	15°	
	10°	75	10°	

Kg / 24h - Water				
	38°	53	32°	
	32°	59	21°	
	21°	68	15°	
	10°	78	10°	

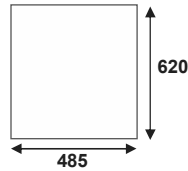

Air



Water

ASGP 78

Stainless steel AISI 304

Dati tecnici – Caractéristiques techniques – Technical specifications – Datos técnicos – Technische Daten

Prod.Kg/24h +10°C - Prod.Lb/24h +10°C		75-165
Prod.Kg/24h +10°C - Prod.Lb/24h +10°C		78-172
Contenitore/Bac/Bin/Depósito/Behälter	Kg/Lb	25-55
Larghezza/Largeur/Width/Anchura/Breite	mm	485
Profondità/Profondeur/Depth/Profundidad/Tiefe	mm	620
Altezza/Hauteur/Height/Altura/Höhe	mm	720
Peso netto/Poids net/Net weight/Peso neto/Nettogewicht	Kg	57
Peso lordo/Poids brut/Gross weight/Peso bruto/Bruttogewicht	Kg	61
Vol. imballo/Vol.embal/Vol.(packed)/Volumen con embalaje/Verpackungsvolumen	m ³	0,32
Alimentazione/Voltage/Voltaje/Anschlussspannung	V/Hz/ph	230/50/1
Compressore/Compresseur/Compressor/Compresor/Kompressor	HP	1/4
Compressore/Compresseur/Compressor/Compresor/Kompressor (T evap.= -10°C)	W	350
Watt - Totale/Total/Total/Total/Gesaint (T = +43°C)	W	520
Calorie/Calorie/Calorie/Caloria/Kalorie cond.	Kcal / h	630
Ampère - Totale/Total/Total/Total/Gesamt	A	3
Fusibile/Fusible/Recommanded fuse/Fusible/Netzsicherung	A	10
Refrigerante/Réfrigérant/Cooling gas/Refrigerante/Kühlmittel	R	290
Carica/Charge/Fill/Carga/Füllmenge	Kg	0,069
eq. CO ₂	Kg	0,207
GWP		3
Carica/Charge/Fill/Carga/Füllmenge	Kg	0,047
eq. CO ₂	Kg	0,41
GWP		3
Entrata acqua/Entrée eau/Water inlet/Entrada agua/Wasseranschluß	Ø	3/4"
Scarico acqua/Vidange eau/Water outlet/Desague/Wasserabfluß	Ø	3/4"
Acqua/Eau/Water/Agua/Wasser - lt / h 21°C / 15°C		3-16
Pressione acqua/Pression eau/Water pressure/Presión agua/Wasserdruck - bar	min / max	1- 6
Temp.ambiente/Temp.ambiant/Ambient temp./Temp.ambiente/Rammtemperatur - °C	min / max	10 - 40
Temp. acqua/Temp. eau/Water temp./Temp. agua/Wassertemperatur - °C	min / max	5 - 35